

# FMX

## MEMBRANE FILTRATION SYSTEM

ON-SITE TRIAL

SCOPE OF WORK & GUIDELINES

for FMX-E5 model with 20' containerized pilot trailer

June 2017



## Technology

Membrane filtration provides an absolute barrier for contaminants, enabling compliance with strict discharge regulations.

FMX is an innovative membrane filtration system that uses high-speed vortex generation to reduce fouling, thereby increasing the effective permeability of the installed membranes. FMX specializes in high density, high viscosity, and high solid applications most typically found in industrial wastewaters. Robust materials of construction enable FMX to be applied to high temperature, acidic/caustic, and abrasive water streams.

The membrane module is constructed with flat sheet, vertically stacked membrane trays. The membrane trays are stationary, and are sandwiched on each side by vortex generators. The vortex generators are veined discs which spin at high RPM. High turbulence keeps solids in suspension and off the membrane surface.

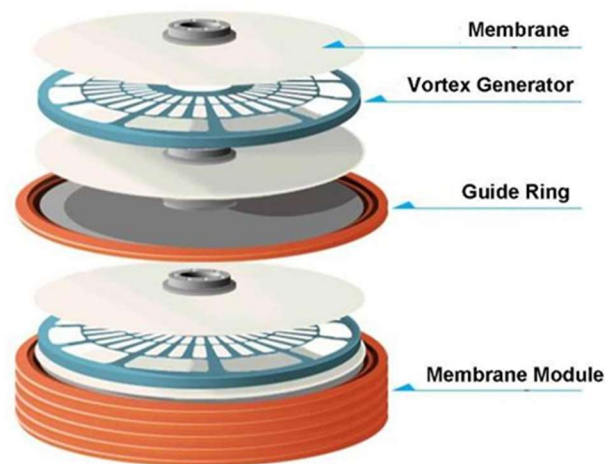

Figure 1: FMX membrane module design where vortex generator spins to minimize fouling on the membrane surface

## Scope of Work

The main objective of the on-site pilot test is to confirm the reproducible and stable performance of the FMX membrane system with readily-available of feed stream to obtain performance data for use in future system design.

After the in-house pilot test has been conducted to identify the main process variables and verify the technical and economical feasibility of the FMX system for the specific application, the next step is to confirm the application of FMX membrane system at greater length and depth during on-site pilot test studies. This pilot test will employ an FMX pilot unit equipped with the previously determined optimal membrane and operating parameters.

During the on-site test, data will continue to be collected to be crosschecked against data collected from the lab during the in-house test. Using the FMX pilot unit, measurements will be taken to check permeate flux, % recovery rate, CIP efficiency, and permeate quality until a baseline has been reached and all performance goals have been met.

Main objectives include:

- Demonstrate FMX technology and confirm long term operation reliability
- Determine % recovery rate at which the results can be repeated with sustainable permeate flow rate
- Formulate optimum cleaning procedures and frequencies and finalize other operating variables
- Measure the effects of repeated cleaning and filtration cycles to estimate the life span of membrane modules
- Obtain reliable scale-up and designing factors for full-scale industrial units
- Use as small-scale filtration/separation apparatus for lower volume operations, and analytical and academic fields

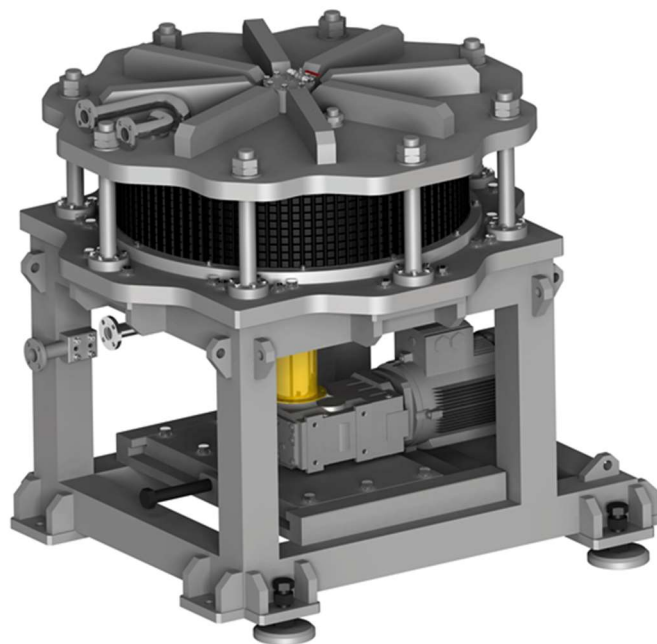

Figure 2: FMX-E5 pilot unit

## FMX-E5 Pilot Unit

The FMX-E5 used for pilot testing has membrane surface area of 61 ft<sup>2</sup> (5.67 m<sup>2</sup>) and a membrane module assembly identical to that of full-scale FMX industrial units. Its fluid dynamics and process designs are intended to simulate full-scale operation for designs and estimation of performance in full-scale operations.

The membrane module is constructed such that the feed stream enters from the bottom into the pressurized membrane module. Operating pressure is modulated and maintained by the feed pump and by a flow control valve on the concentrate line. Permeate passes through the membrane disks into the drainage cloth where the filtered liquid is collected. The drain cloth is an incompressible plastic that allows permeate flow under the outer O-ring, which prevents concentrate from mixing with the permeate. All reject material exits from the top of the membrane module.

FMX-E5 PILOT UNIT SPECIFICATIONS	
Membrane Surface Area	61 ft <sup>2</sup> (5.67 m <sup>2</sup> )
Membrane Type	MF / UF
Maximum Throughput	6 GPM (1.4 m <sup>3</sup> /hr - based on 250 LMH flux)
Maximum Feed Pressure	71 PSI (5 kg/cm <sup>2</sup> )
Maximum Feed Temperature	Approx. 160°F (70°C, depending on selected membrane's limitation)
pH Range	1.5 – 11.5 in filtration mode / 1.5 – 12.5 in CIP mode (depending on selected membrane's limitation)
Rotation Speed	210 RPM
Rotation Drive Motor	40 hp (30 kW) / 480V 60Hz 3 Phase
Materials of Construction	Fiberglass reinforced plastic; carbon steel
Materials of Elastomer	EPDM (other elastomers available upon request)
Hold-Up Volume	24 gallons (90 L)
Dimensions (L x W x H)	6'1" x 4'7" x 5'6" (1.86 m x 1.41 m x 1.68 m)
Dry Weight	9,900 lbs (4,500 kg)

## Suggested On-Site Trial Timeline

TIMELINE	ACTION ITEMS	DELIVERABLES
Pre-Trial	<ul style="list-style-type: none"> <li>- logistics</li> <li>- site location</li> <li>- utilities requirement</li> <li>- piping and holding tanks</li> <li>- test plan &amp; operation parameters</li> <li>- supporting equipment &amp; manpower</li> </ul>	<ul style="list-style-type: none"> <li>- On-Site Trial Scope of Work</li> <li>- On-Site Testing Plan</li> <li>- Packing List</li> </ul>
Set-Up & Training (week 1)	<ul style="list-style-type: none"> <li>- electrical power connection</li> <li>- piping, hosing, and destination tanks setup</li> <li>- startup, initial testing, data collection</li> <li>- FMX technology introduction</li> <li>- operation training</li> </ul>	<ul style="list-style-type: none"> <li>- On-site Test Guideline</li> <li>- FMX-E5 Containerized Pilot Trailer Manual</li> </ul>
Operation (week 2-4)	<ul style="list-style-type: none"> <li>- confirm sustainable operation</li> <li>- data collection</li> </ul>	<ul style="list-style-type: none"> <li>- Remote support</li> </ul>
Conclusion (week 4)	<ul style="list-style-type: none"> <li>- complete various tests</li> <li>- organize test data</li> <li>- arrange logistic for packing up</li> </ul>	<ul style="list-style-type: none"> <li>- Packing and shipping instructions</li> </ul>
Post-Trial	<ul style="list-style-type: none"> <li>- data and costs analysis</li> <li>- determine CAPEX &amp; OPEX</li> </ul>	<ul style="list-style-type: none"> <li>- On-Site Pilot Test Report</li> <li>- Budgetary Proposal</li> </ul>

## Fees and Services

The cost of an on-site trial for FMX-E5 containerized pilot system is \$20,000 per month. This fee includes services below:

- 5 working days, including traveling time, of BKT engineers to setup the pilot unit, confirm operations, and train client's staff at the facility.
- continuing remote support from BKT staff during the remainder of the trial.
- optimization of CIP (clean-in-place) cycle for chemical choice and frequency.
- confirmation of membrane performance under regular and upset condition at client's site
- technology explanation & demonstration
- crane service and trucking of containerized pilot system, and travel expense and additional tech time of BKT engineers are not included and will be billed to the client as a cost of on-site testing.



## Appendix 1 | Specificatin of Containerized Pilot Trailer

### CONTAINERIZED PILOT TRAILER SPECIFICATIONS

Type	20 ft. standard dry container
External Dimensions (L x W x H)	19'10" x 8'0" x 8'6" (6.06 m x 2.44 m x 2.60 m)
Internal Dimensions (L x W x H)	19'2" x 7'8" x 7'9" (5.84 m x 2.35 m x 2.39 m)
Door Opening (W x H)	7'8" x 7'5" (2.34 m x 2.28 m)
Dry Weight	Approx. 18,000 lbs (8,200 kg)
Feed/CIP Pump	- Grundfos single-stage centrifugal pump - 5.5 kW, 380 VAC, 60 Hz, 3500 RPM - rated flow 26.7 m <sup>3</sup> /h - rated head 44.9 m
Control Panel	Automated PLC control with PC-based touchscreen HMI (NEMA 2)
CIP Tank	265 gallons (1,000 L) fiberglass tank with built-in heaters
Power Supply	480 VAC / 60 Hz / 3 phase / 100 Amp (max)

## Appendix 2 | Packing List

EQUIPMENT	QTY	NOTE
20' Containerized Pilot Trailer	1	- self-contained and automated pilot trailer with FMX-E5, feed/CIP pump skid, control panel, CIP tank, and 380V-to-480V stepup transformer
FMX-E5 Pilot Unit	1	- with pre-selected membrane trays installed
Tool Box	1	- essential hand tools for maintianing FMX-E5 unit

# Appendix 3 | P&ID of FMX-E5 Pilot Trailer

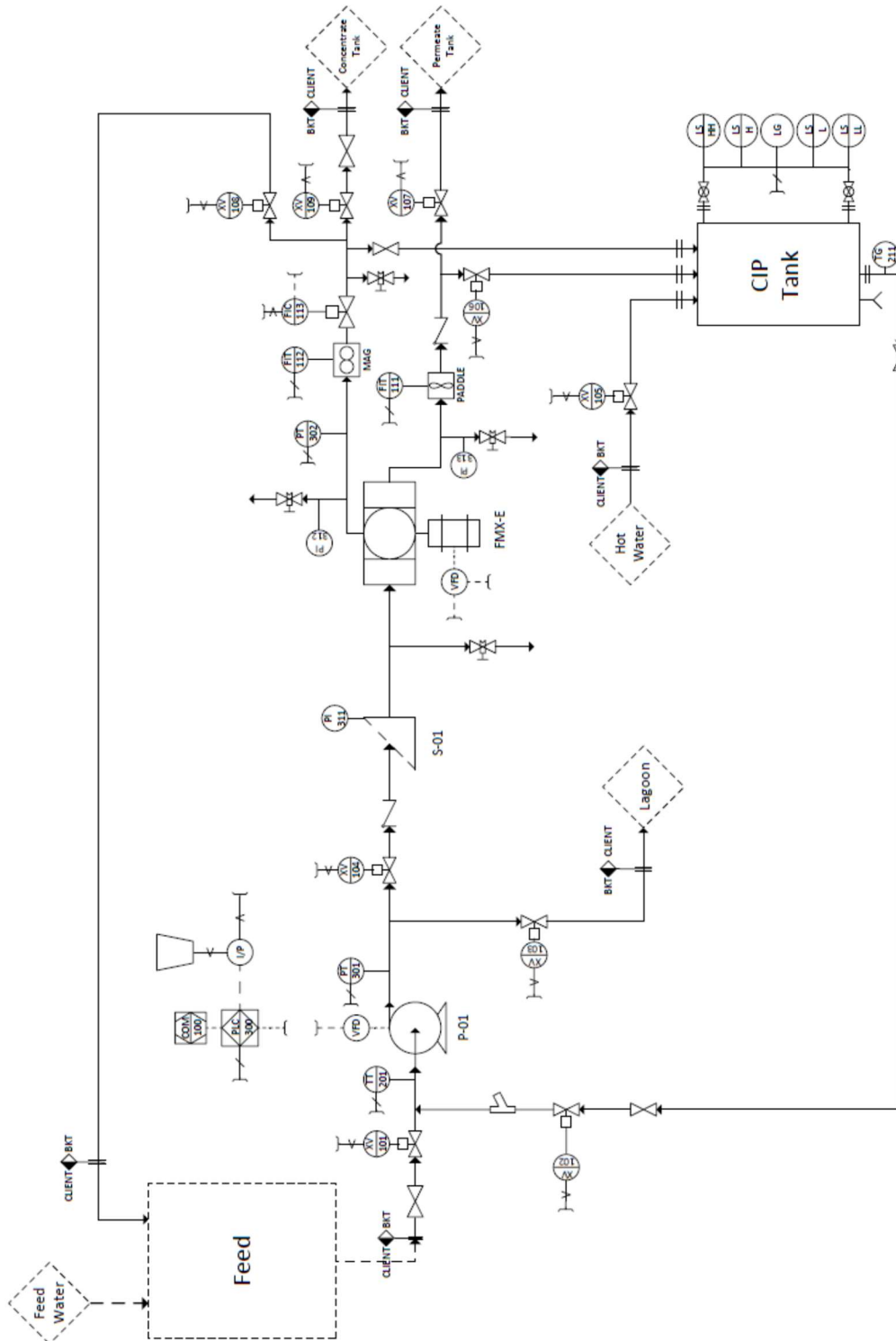

Figure 3: FMX-E5 pilot trailer P&ID

## Appendix 4 | 3D Layout of FMX-E5 Pilot Trailer



Figure 4: 3D layout of FMX-E5 pilot trailer  
(two auxiliary tanks are for reference and not included with the pilot trailer)





## Appendix 5 | On-site Pilot Test Equipment Lease Agreement